

A530 - ALUMINUM GEARED HINGE, 3/32" INSET, HALF SURFACE

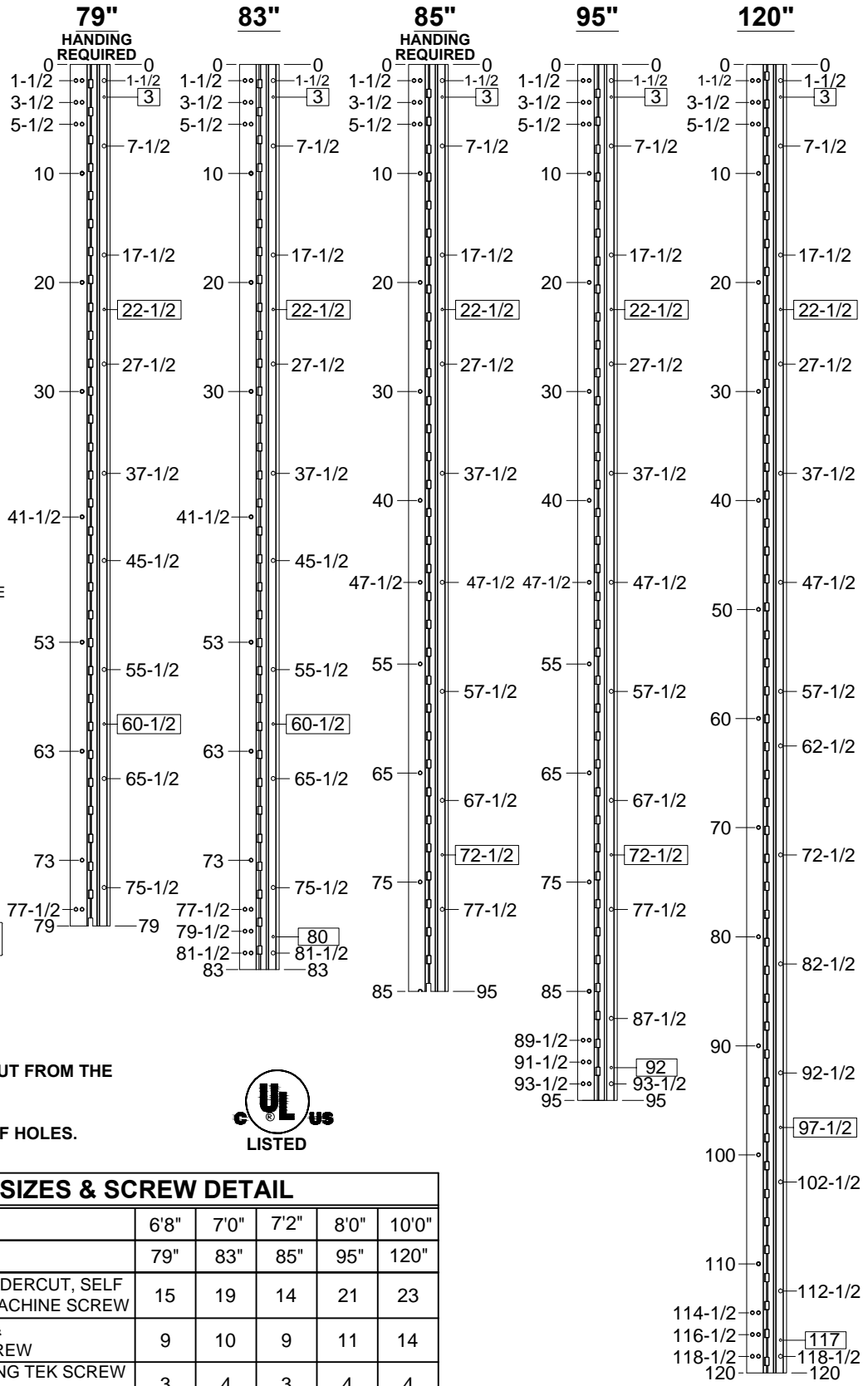

NOTES:

1. HINGES CUT TO CUSTOM LENGTH ARE CUT FROM THE BOTTOM. PLEASE SPECIFY HANDING.
2. ALL DIMENSIONS ARE IN INCHES.
3. ALL DIMENSIONS ARE TO CENTERLINE OF HOLES.
4. "XX" DENOTES LOCATOR HOLE.

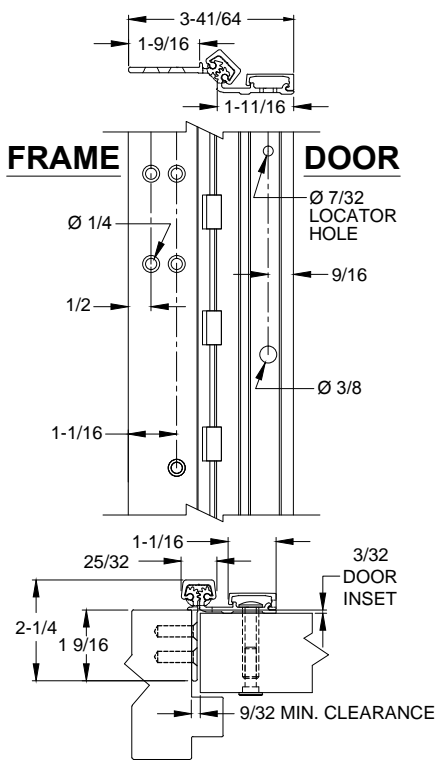

STANDARD HINGE SIZES & SCREW DETAIL

NOMINAL DOOR HEIGHT	6'8"	7'0"	7'2"	8'0"	10'0"
ACTUAL HINGE LENGTH	79"	83"	85"	95"	120"
FRAME	12-24 x 7/8" PHILLIPS FLAT HEAD, UNDERCUT, SELF DRILLING, THREAD FORMING TEK MACHINE SCREW				
DOOR	1/4-20 x 1-9/16" x 3/8 DIA. SEX BOLT & 1/4-20 x 1" PH. HEAD SHOULDER SCREW				
	12-24 x 7/8" PH. PN. HD. SELF DRILLING TEK SCREW (LOCATOR HOLE)				

A530-ALUMINUM GEARED HINGE-01.DWG



www.abhmf.com
 E-mail: abhinfo@abhmf.com
 Architectural Builders Hardware Mfg., Inc.
 1222 Ardmore Ave., Itasca, IL 60143
 630.875.9900; FAX 800.9FAXABH (932.9224)

A530
ALUMINUM GEARED HINGE

©2017 ABH Mfg., Inc.
 printed in USA

PAGE 1 OF 1
 ISSUED 10-27-17